

—INTECO—

WE ARE INTECO

APLAN[®]
process oriented automation





WE ARE NOT THAT EASY TO FIND



WE ARE TRADITION



WE ARE
METALLURGY



INTECO Headoffices



—INTECO—
TBR CASTING

advanced refractory
ART
technologies

—INTECO—
Italy

melting&casting
INTECO
technologies

—INTECO—
Beijing

—INTECO—
PTI
process technology international

—INTECO—
Dalian

—INTECO—
India

TECTRADE
—Handelsgesellschaft mbH—

—INTECO—
FUCHS

APLAN®
process oriented automation

—INTECO—
siderimpes

The INTECO Group



OUR ASSETS

Engineering

- › 3D engineering
- › FEM & CAD analysis
- › Planning & feasibility studies
- › Project management & technical assistance

Partners

- › Highly qualified manufacturing plants
- › Metallurgical universities in Europe
- › Experts for process modelling & simulation
- › Technological experts & metallurgical consultants

Expert Know How

- › Melting and casting technology in all fields of the steel industry

INTECO's Product Portfolio



PROCESS KNOW-HOW & CONSULTING

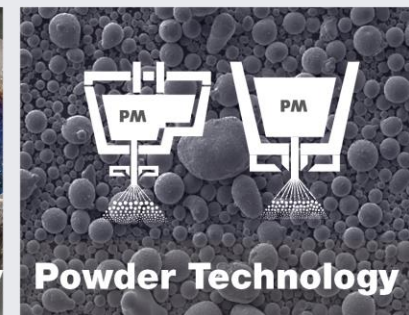
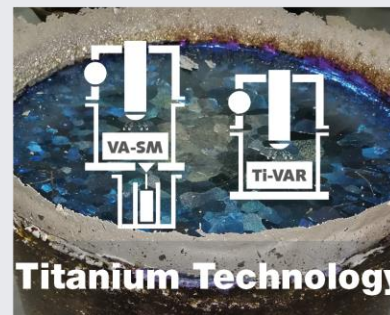
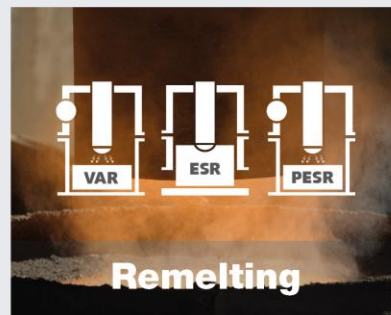

PROCESS KNOW-HOW & CONSULTING

DIGITAL SOLUTIONS &
INDUSTRIE 4.0

DIGITAL SOLUTIONS &
INDUSTRIE 4.0



—INTECO—

EAF – ELECTRIC ARC FURNACE



www.inteco.at

PORTFOLIO & FEATURES

- ›  technologies since 2015
- › Tapping weights from 2 to more than 300 t
- › Split Fe-Cu water cooled upper shell panels and roof panels
- › Three points or single point roof lifting
- › Swing bridge with roller bearing or king pin
- › Copper or aluminum conductive arms
- › Combined raw material input design (Scrap, DRI/HBI, Hot Metal)
- › Hot heel size from 0% to 40% tapping weight
- › UHP index from 0.5 to 1.5 MVA/t
- › From single charge to multi bucket charge
- › Tapping systems with EBT tap hole or tapping spout
- › Tailor made design and process technologies



| SAF

—INTECO—

BOSTON
METAL
BRASIL

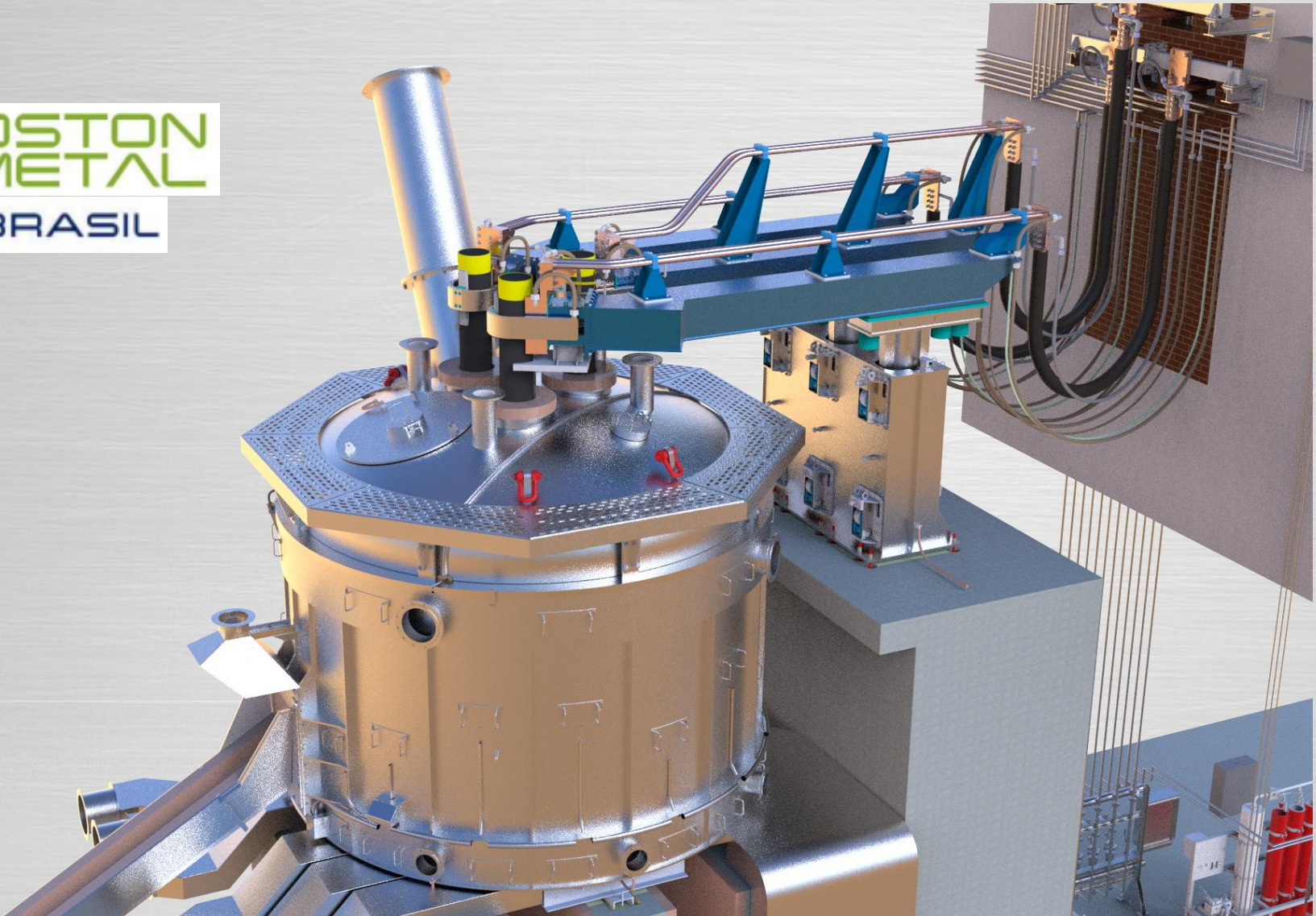

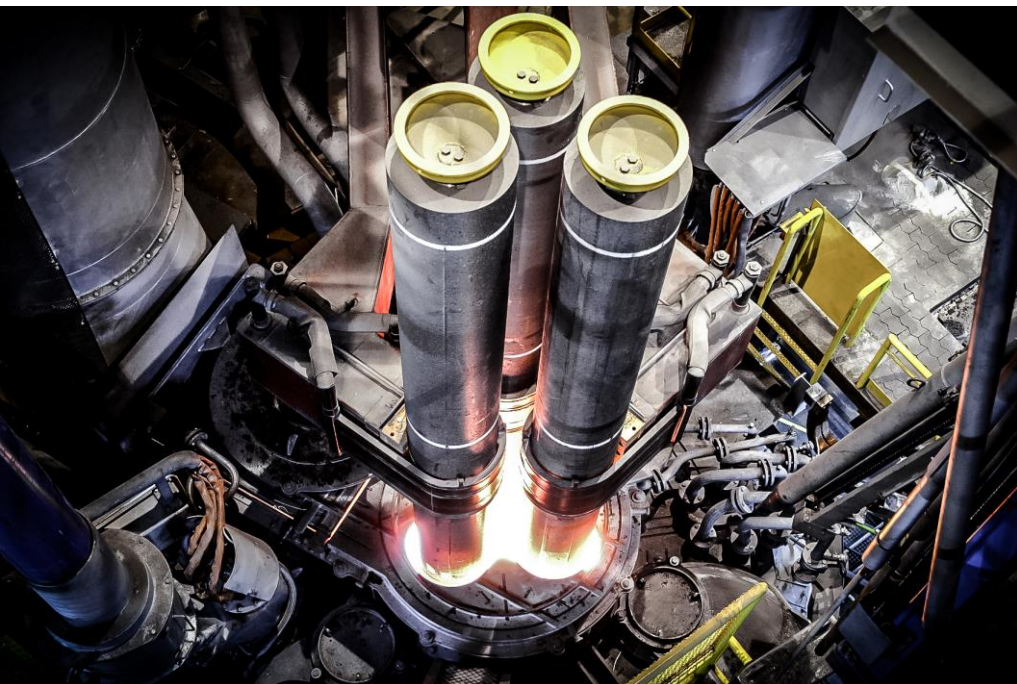

LF – LADLE FURNACE

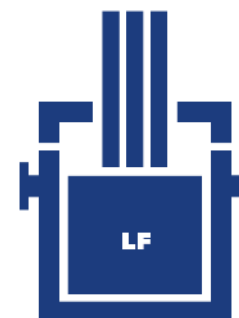

LF

—INTECO—

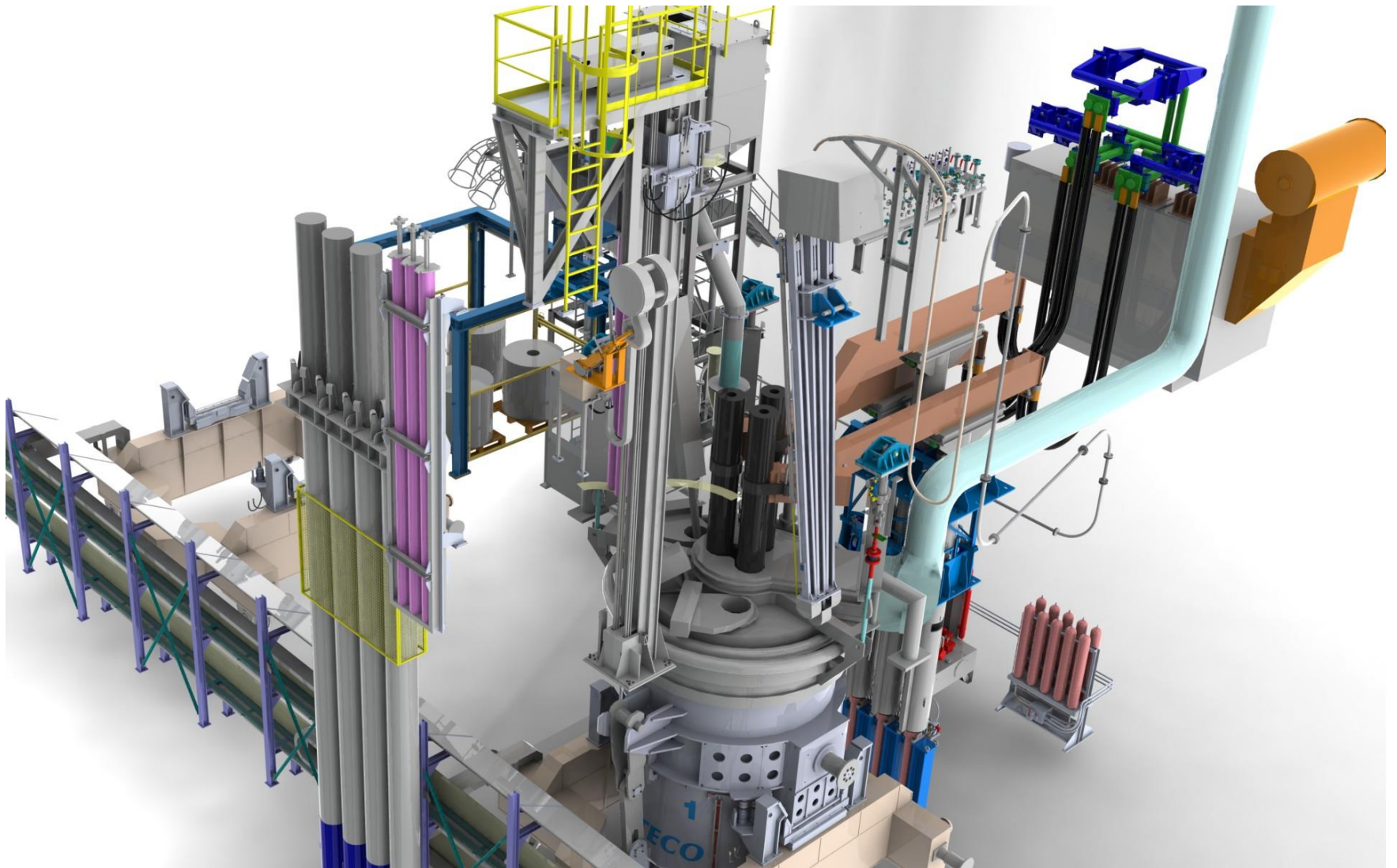

LF and EAF

ISEC – Electrode Regulation

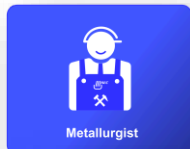

Metallurgist

- › increase PRODUCTIVITY
 - › max active power input

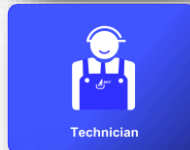

Technician

- › best ENERGY EFFICENCY
 - › less losses

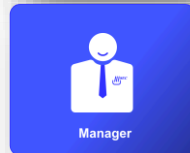

Manager

- › less ELECTRODE- AND REFRACTORY CONSUMPTION
 - › less consumables

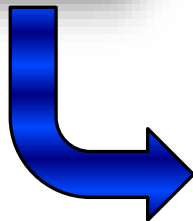

- › arc stability
- › right working point
- › covered arc (foaming slag control)
- › right operating profile



LF

—INTECO—

Wire Feeding Machine

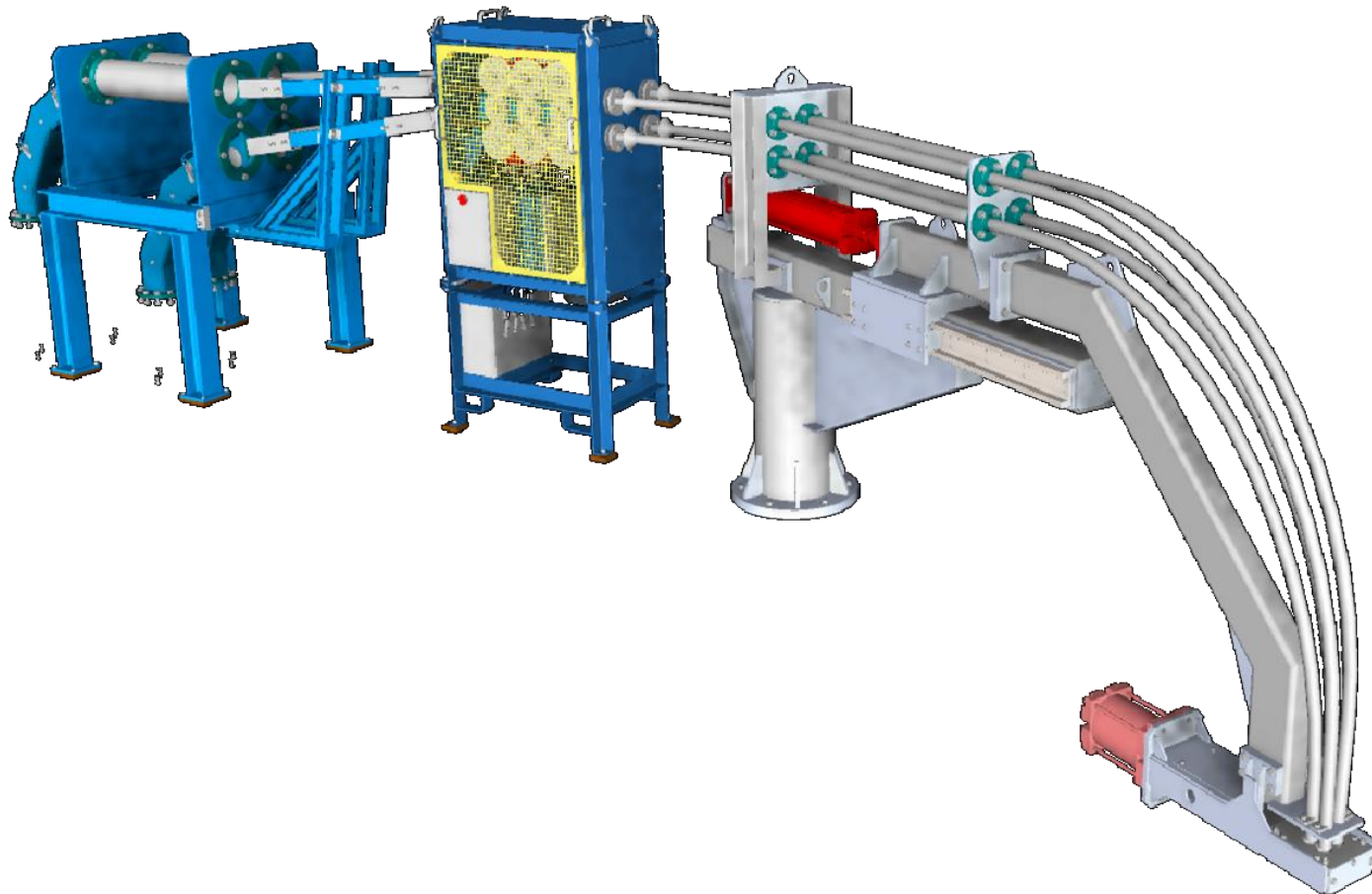



VD/VOD – VACUUM (OXYGEN) DEGASSING



VD/VOD

PORTFOLIO & FEATURES

- › Single or twin vacuum vessel operation stand
- › Heat sizes 3 to 350t
- › Steam ejector vacuum pumps
- › Dry mechanical vacuum pumps
- › Alloying under vacuum conditions

USP's OF INTECO DESIGN

- › Complete in house design
- › VOD ladle cover with flat inner surface (steel plates or copper plated)
- › Automatic gas coupling system (proved design to work in vaccum)
- › Stuffing box for oxygen lance (INTECO Patent)
- › All auxiliary equipment out of one hand

VD/VOD





DETEM VD/VOD – VACUUM (OXYGEN) DEGASSING

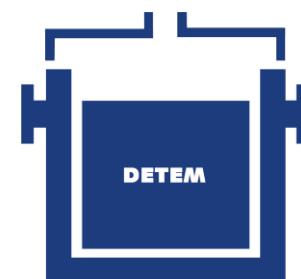

DETEM VD/VOD

PORTFOLIO & FEATURES

- › Ladle degassing plants for small steel plants and foundries
- › Heat sizes 3 to 20t
- › Steam ejector vacuum pumps
- › Dry mechanical vacuum pumps
- › Alloying under vacuum conditions

USP's OF INTECO DESIGN

- › Best CAPEX and OPEX due to optimized design
- › VOD ladle cover with flat inner surface (steel plates or copper plated)
- › Same metallurgical treatments as in larger VD/VOD's possible
- › Stuffing box for oxygen lance (INTECO Patent)
- › All auxiliary equipment out of one hand



RH DEGASSING



RH

PORTFOLIO & FEATURES

- › Single or twin RH vessel operation station
- › RH vessel fast exchange system
- › Steam ejector vacuum pumps
- › Dry mechanical vacuum pumps
- › Snorkel maintenance car

USP's OF INTECO DESIGN

- › Complete in house design
- › Ladle- or RH vessel lifting system
- › TOP-burner & O₂-blowing lance system
- › Variable dust separating/cooling system
- › Integration in existing steel plants



CC – CONTINUOUS CASTING



CC

PORTFOLIO & FEATURES



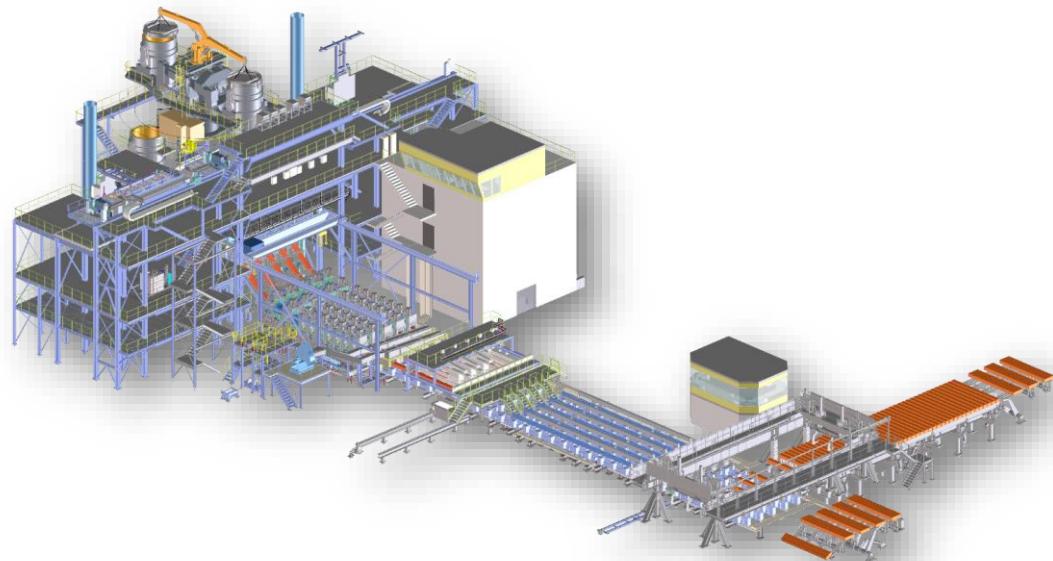

- › Bow type or vertical bending/unbending machines
- › Vertical casting machine
- › Horizontal casting machine
- › Segment casters



CC

Mould Level Control

Components:

-  **Stopper Rod Mechanism**
-  **Hot Area Servo Drive**
-  **Mould Level Master**
-  **Emergency Slide Gate**
-  **Subentry Shroud Changer**

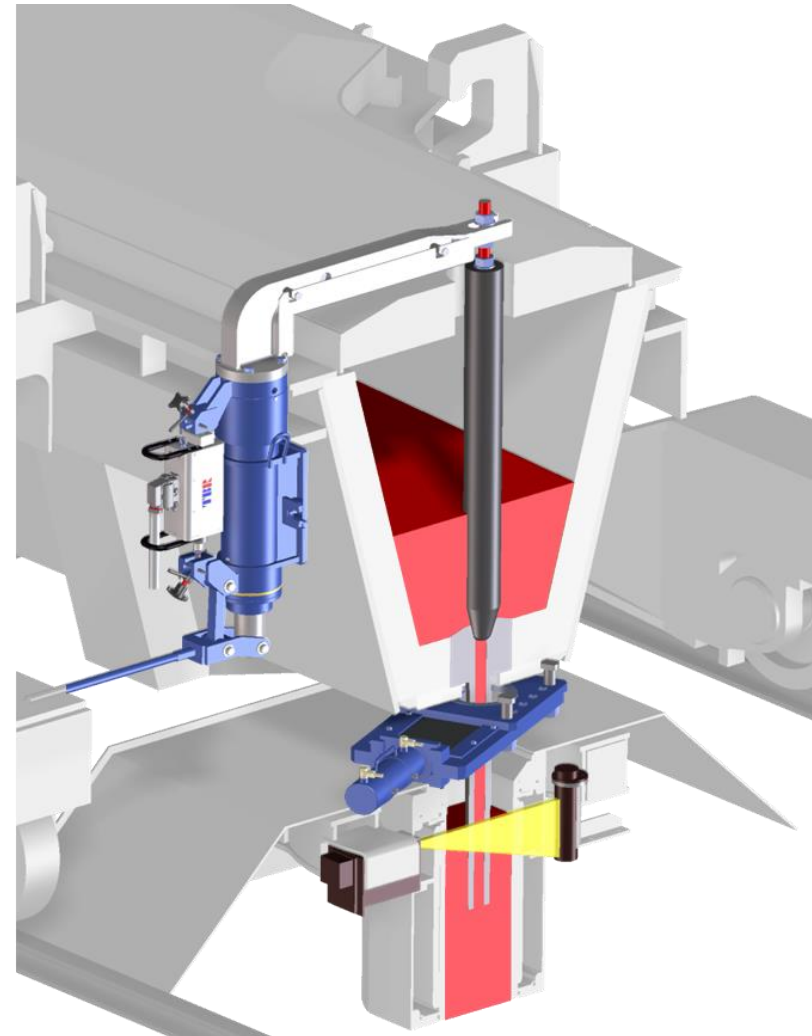



VIM – VACUUM INDUCTION MELTING





—INTECO—

ESR – ELECTROSLAG REMELTING



www.inteco.at



VAR – VACUUM ARC REMELTING



INTECO - Brazil

Clients - Projects

- › Barro Alto – FeNi Refinery – Anglo American
- › Onca Puma – FeNi Refinery – Vale
- › Boston Metals Brazil – SAF 15t slag
- › Boston Metals Brazil – SAF 45t slag
- › Villares – WFM, Scrap EAF, ESR-control
- › Araguaia – FeNi Refinery – Horizonte Minerals.
- › CSP – WFM
- › Ternium Brazil – Gas Coupling system
- › Valourec – Water Coupling System EAF
- › Codemin – FeNi Refinery – Anglo American
- › AM – Barra Mansa – Gas Coupling System
- › SIMEC Pinta – Consulting Service
- ›Gas Coupling System.....

Partner

- › APLAN – Belo Horizonte

World Class Customers



—INTECO—



THANK YOU !

DISCLAIMER



INTECO melting and casting technologies GmbH

Wienerstrasse 25
A-8600 Bruck a.d. Mur

Tel.: +43 (0)3862 53110 0
Fax: +43 (0)3862 53844
Email: inteco.austria@inteco.at

Have an eye on our technology www.inteco.at

© INTECO melting and casting technologies GmbH.
All rights reserved.

The content of this presentation is subject to copyright. Unauthorized use, reproduction or transfer of the content, or of parts of this content, is prohibited. Please contact the publisher concerning permission to use the content.